

Sizing Optimization and Techno-Economic Analysis of a Hybrid Renewable Energy System Using HOMER Pro Simulation

Sonu Kumar^{1,2}, C Sethuraman^{1,3*} and Chandru G⁴

¹Academy of Scientific and Innovative Research (AcSIR), Ghaziabad 201 002, Uttar Pradesh, India

²CSIR-Structural Engineering Research Centre (SERC), Chennai 600 113, Tamil Nadu, India

³CSIR-Central Scientific Instruments Organisation (CSIO), CSIR Madras Complex, Chennai 600 113, Tamil Nadu, India

⁴SRM Easwari Engineering College, Ramapuram, Chennai 600 089, Tamil Nadu, India

Received 18 March 2021; Revised 24 June 2021; Accepted 01 September 2021

Hybrid renewable energy system (HRES) is the integration of multiple energy generating systems installed to generate energy from the renewable sources such as Solar Photovoltaic (PV), wind, bio-generator etc. It is very prudent to determine viable combinations, optimum sizing and to have a techno-economic analysis of HRES before its procurement and installation. In this study two optimum system was modelled using HOMER Pro (open-source version) to meet the electrical load demand of an institution located in Chennai (12.59°N and 80.14°E) and to get the minimum Net Present Cost (NPC) of the proposed system. Based on the modeling, for optimum-1 system the capacity factor and contribution percentage of PV, wind turbine and bio-generator was found to be 79.41%, 0.98%, 19.61% and 92.83%, 0.43%, 6.75%, respectively. And for optimum-2 system, it was 85.86%, 2.02%, 12.12% and 93.31%, 0.82%, 5.87%, respectively. Sensitivity analysis was carried out to find out the variations on NPC and Cost of Energy (COE) by adjusting the cost of PV, wind turbine, battery, converter, bio-generator and fuel, from 0.8 to 1.2 times of its present cost. Based on HOMER Pro simulation, the most feasible system obtained was optimum-1 which consists of 81 kW photovoltaics, 1 kW wind turbine, 20 kW biogas generator, 47.3 kW converter and lead acid battery (rated 101 Ah/12 V-150 numbers) with NPC at \$ 1,84,687 to generate energy 1,35,978 kWh per year.

Keywords: Cost of energy, HOMER Pro, HRES, Net present cost, Sensitivity analysis

Introduction

Providing reliable and uninterruptible power supply to all Indian citizens is one of the major challenges in our country since many remote areas are still not having access to grid connected power supply. Sustainable development in these remote areas is possible only by ensuring availability of grid supply or affordable, reliable and decentralized power supply. To overcome the challenges, multiple renewable energy sources with an optimum size needs to be integrated.¹ Integrated energy systems have various advantages such as efficient resource management, increased energy production, proper load management, lesser operational and maintenance cost and lesser emission release to the environment.^{2,3} Renewable sources of energy like solar, wind and bio-energy are the best alternatives for providing reliable power to the remote locations. However, selection of components and optimum sizing based on

available energy resources is very important for providing the cost-effective solution.

Effective integration of multiple energy sources has been gaining an importance among the researchers since past few decades to solve the techno-economic barriers by using the distributed renewable energy systems.⁴⁻¹¹

Many of research works were executed to develop the efficient techniques like iterative technique^{12,13}, genetic algorithm¹⁴, hybrid genetic algorithm¹⁵, graded particle swarm optimization (GPSO)¹⁶, meta-PSO¹⁷, mixed-integer quadratic programming technique¹⁸, graphical construction technique¹⁹ and probabilistic approach²⁰ for size and cost optimization as well as efficiency improvement. One of the common tools used for energy planning and cost optimization is HOMER Pro.²¹ It is used to perform various functions such as simulation, optimization, net present cost (NPC), loss of power supply probability (LPSP) and sensitivity analysis.²²

In this paper, authors have optimized the HRES using multi-objective HOMER Pro (open-source

*Authors for Correspondence
E-mail: sethuenergy@csircmc.res.in

version) and presented the result of size optimization, net present cost, techno-economic analysis and sensitivity analysis. HRES annual energy generation was studied with different combinations of HRES and obtained optimum economically feasible system on the basis of minimum net present cost (NPC). The design cost of the hybrid system includes the costs for initial capital, replacement, O&M, fuel, salvage and interest spent on project lifetime.²³⁻²⁵

HRES system description and Methods

The hybrid system model designed in HOMER Pro for simulation purpose is given in Fig. 1. This HRES comprises of wind turbine, solar panel, battery energy storage system, biogas generator, converter and loads as per the energy demand of the selected institution. The annual average energy demand is 256.33 kWh/day, and peak demand is 71.37kW.

Resource Availability

The selected site location of the institution in Homer Pro for simulation purpose is located at 12°59.2' N latitude and 80°14.8' E longitude. The solar and wind resource availability at the selected site is given in Fig. 2 and 3 respectively.

Annual average global horizontal solar radiation at this location is 5.23 kWh/m²/day. Monthly average global horizontal solar radiation is in the range of 4.06 to 6.72 kWh/m²/day. Monthly average wind speed is in the range of 3.56 to 5.52 m/s, and annual average wind speed at this location is 4.70 m/s.

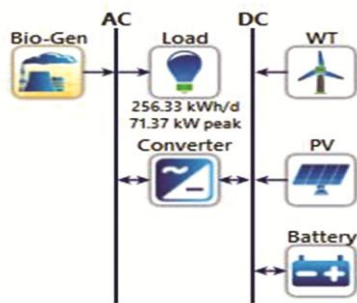

Fig. 1 — Hybrid system model designed in Homer Pro

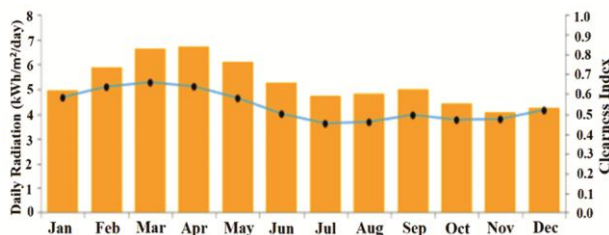

Fig. 2 — Solar resource availability at selected site²⁶

Load Demand Profile

The average load demand pattern for the selected institute was taken from the energy management system installed at the institute, which records every minute power consumption data for the whole year. The average daily based annual energy demand is 256.33 kWh/day, total annual energy demand is 90841 kWh/year and maximum peak load demand is 71.37 kW.

The institutional hourly-wise average load pattern is given in Fig. 4. Continuous load pattern recorded in every day from January to December 2019 is given in Fig. 5. Monthly based hourly loading pattern taken during weekdays and weekends is given in Fig. 6 and Fig. 7 respectively.

The continuous load pattern recorded from January to December 2019 can be seen from Fig. 5.

Results and Discussion

Optimum sizing and Techno-Economic Analysis using HOMER Pro

In order to meet the required maximum peak i.e. 71.37 kW load as mentioned in the previous section

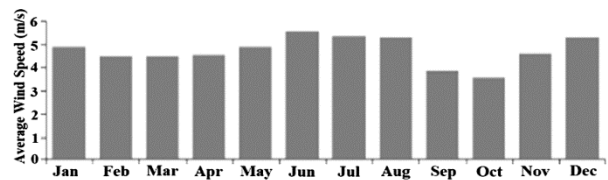

Fig. 3 — Wind resource availability at selected site²⁷

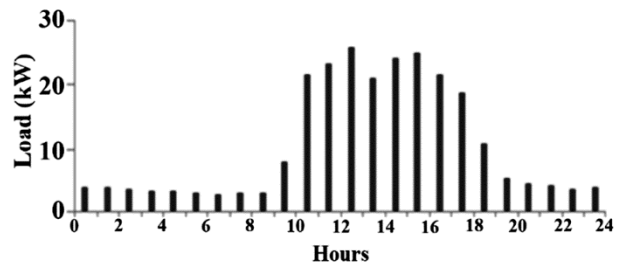

Fig. 4 — Institutional hourly-wise average load pattern

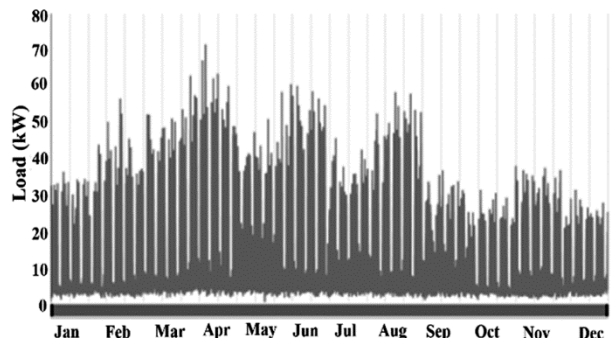

Fig. 5 — Institutional load demand pattern over full year

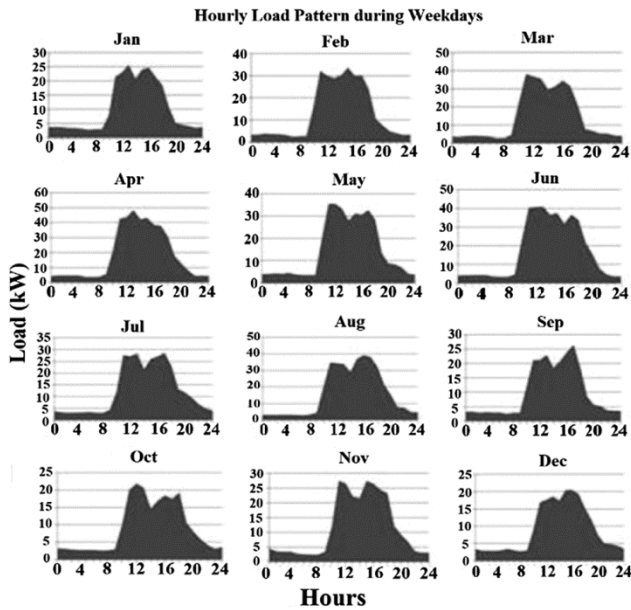

Fig. 6 — Monthly based hourly loading pattern during weekdays for the year 2019

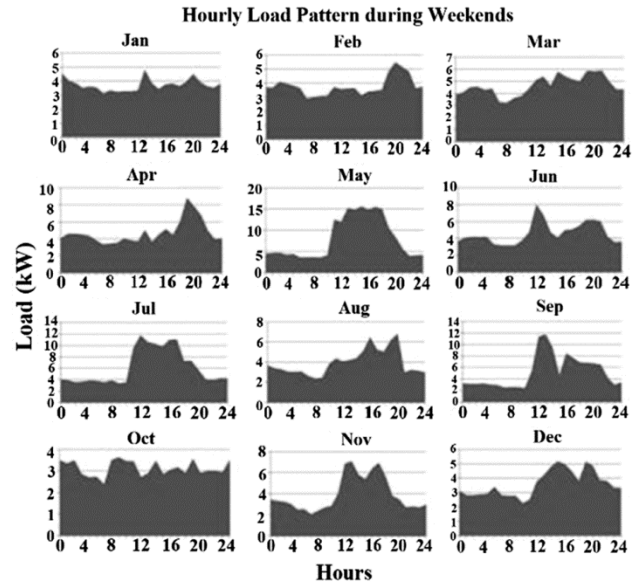

Fig. 7 — Monthly based hourly loading pattern during weekends for the year 2019

Architecture							Cost				Bio-Gen	PV	WT
PV (kW)	WT	Bio-Gen (kW)	Battery	Converter (kW)	COE (US\$)	NPC (US\$)	Operating cost (US\$/yr)	Initial capital (US\$)	Production (kWh)	Production (kWh/yr)	Production (kWh/yr)		
81.0	1	20.0	150	47.3	₹ 0.159	₹ 1,84,687	₹ 6,154	₹ 1,06,015	9,181	1,26,220	577		
81.9		20.0	151	46.9	₹ 0.159	₹ 1,84,691	₹ 6,157	₹ 1,05,984	9,157	1,27,656			
83.4		12.0	158	45.8	₹ 0.159	₹ 1,84,722	₹ 6,319	₹ 1,03,939	8,333	1,30,025			
80.8		15.0	164	47.0	₹ 0.159	₹ 1,84,724	₹ 6,342	₹ 1,03,651	8,651	1,25,985			
83.2		15.0	148	49.5	₹ 0.159	₹ 1,84,789	₹ 6,230	₹ 1,05,143	8,581	1,29,727			
80.0		15.0	165	48.9	₹ 0.159	₹ 1,84,795	₹ 6,368	₹ 1,03,386	8,585	1,24,772			

Fig. 8 — Optimization result obtained from HOMER Pro

and optimum sizing has to be done by the designer by identifying the suitable combination of renewable energy systems components consisting of solar, wind, bio-gen, battery and converter. Also, the designer has to provide the necessary inputs such as capacity, quantity, life time, efficiency, throughput, average energy, peak and average load and cost required for capital; replacement; O&M etc. in the HOMER Pro.

Based on the given input, the results obtained for system optimization consisting of all the renewable energy sources (solar PV, wind turbine, bio-gen) and components (battery, converter) cost details such as cost of energy (COE), net present cost (NPC), operating cost and capital cost, details of energy sources in a year is shown in Fig. 8. The optimization results obtained for HRES consists of a large number of possible combinations of all the three sources as well as an individual energy source alone. Since, in

this present simulation study, it was decided to have compulsory combination of solar-wind-bio-gen and out of large possible combinations obtained, the preference was given to select wherever all three energy sources are reflected and out of which top-10 results are selected for analysis. The details of results obtained can be seen in Table 1 and Table 2.

The optimization results show that most feasible system configuration (termed as Optimum-1) can be selected based on minimum NPC value consists of 81 kW photovoltaics; 1 kW wind turbine; 20 kW biogas generator; 47.3 kW converter; 101 Ah, 12 V, 150 numbers of lead acid battery. The cost factors of optimum-1 is US \$ 0.159, US \$ 184687, US \$ 6154 and US \$ 106015 for COE, NPC, operating cost and initial capital cost respectively. The optimum-1 HRES can generate 1,35,978.1 kWh of energy which can easily be met the annual energy demand i.e. 90,841 kWh/year required for an institution. The capacity

Table 1 — The results of different configuration and cost details of top-10 viable combination of HRES based on NPC

Solar PV (kW)	WT (kW)	Bio-Gen (kW)	Battery (nos.)	Converter (kW)	COE (\$)	NPC (\$)	Operating cost (\$/yr)	Initial capital (\$)
81.00	1	20	150	47.30	0.1590	184687.0	6154.00	106015.0
82.56	1	12	159	45.05	0.1587	184814.5	6324.01	103972.5
83.32	1	12	155	45.40	0.1587	184904.3	6294.18	104443.5
84.14	1	20	132	48.96	0.1594	184917.8	6024.58	107903.5
82.94	1	12	156	46.09	0.1587	184997.7	6312.29	104305.4
82.90	2	20	134	48.78	0.1594	185049.5	6046.04	107760.8
82.47	2	20	136	49.13	0.1594	185116.3	6065.20	107582.7
80.69	4	20	136	48.74	0.1595	185147.0	6064.39	107623.8
82.64	4	12	140	48.05	0.1590	185199.7	6208.04	105840.0
85.00	2	12	140	47.41	0.1590	185315.0	6199.00	106070.9

Table 2 — Different configuration of top-10 viable combination of HRES based on annual energy generation

Solar PV (kW)	WT (kW)	Bio-Gen (kW)	Battery in (nos.)	Converter (kW)	Bio-Gen (kWh/yr)	Solar PV (kWh/yr)	WT (kWh/yr)	Total Annual Energy (kWh)
85.00	2	12	140	47.40	8336.86	132407.8	1154.18	141898.8
84.39	1	20	134	48.05	9225.18	131559.7	577.09	141362.0
84.49	2	12	141	48.23	8339.45	131716.1	1154.18	141209.7
84.14	1	20	132	48.96	9171.44	131163.1	577.09	140911.6
84.42	1	12	152	45.40	8294.30	131601.6	577.09	140473.0
82.90	2	20	134	48.78	9248.92	129235.6	1154.17	139638.7
82.64	4	12	140	48.05	8379.39	128828.2	2308.35	139515.9
82.47	2	20	136	49.13	9190.08	128561.6	1154.17	138905.9
83.32	1	12	155	45.40	8327.86	129891.1	577.09	138796.1
82.81	1	15	147	49.60	8607.65	129086.0	577.09	138270.7

factor and percentage contribution in terms of annual energy generation by solar photovoltaic, wind turbine and biogas generator are 79.41%, 0.98%, 19.61% and 92.83%, 0.42%, 6.75% respectively.

The optimization results show that most feasible system configuration (termed as optimum-2) selected based on maximum energy generation

(out of this top-10 combinations) consists of 85 kW Photovoltaics; 2 kW wind turbine; 12 kW biogas generator; 47.4 kW converter; 101 Ah, 12 V, 140 numbers of lead acid battery. The cost factors of optimum-2 is US \$ 0.159; US \$ 185315; US \$ 6199 and US \$ 106070.9 for COE; NPC; operating cost and initial capital cost respectively. The optimum-2 configuration has NPC value, US \$ 628 higher than the optimum-1 system. At the same time the optimum-2 generates 1,41,898.8 kWh of energy, which is 5920.7 kWh higher than optimum-1 system. The equivalent cost of excess energy generated by the optimum-2 is US \$ 941.39.

The excess energy generated in this proposed optimum-2 system can be either supplied to the neighboring buildings/institutes or can be exported to the grid. The capacity factor and percentage contribution in terms of annual energy generation by solar photovoltaic, wind turbine and biogas generator are 85.86%, 2.02%, 12.12% and 93.31%, 0.82%, 5.87% respectively.

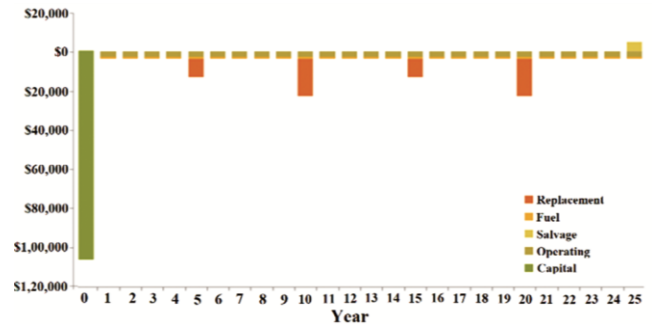

Fig. 9 — Flow analysis of total cost for optimum-1 system

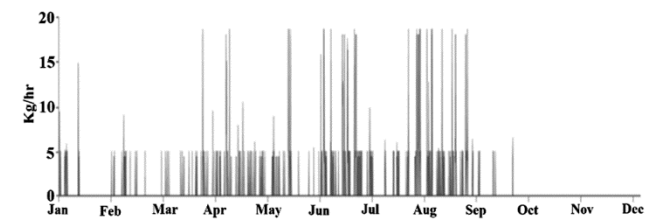

Fig. 10 — Fuel consumption on bio-generator of optimum-1

Out of two systems optimized using HOMER Pro optimum-1 system can be selected for implementation based on minimum NPC. The cost breakup of the two optimized systems i.e. optimum-1 and optimum-2 are described. For optimum-1 system the cash flow analysis of total cost analysis for 25 years of project life time is given in Fig. 9, fuel consumption of bio-generator is given in Fig. 10, monthly power

generation is given in Fig. 11, annual power served to the load by optimum-1 system is given in Fig. 12.

In this HRES bio-generator will be kept under operation whenever there is no or less power availability from other sources. In general, it is observed from Fig. 10, that it is kept under operation for less number of days in the month of January, February and March. From April to September operated for more number of days. Whenever the bio-generator kept for continuous operation, it consumes fuel about 20 kg/hr and on an average it consumes 5 kg/hr. It can be seen from Fig. 11, that the optimum-1 system generate month-wise power higher than the month-wise institutional load demand.

With this combination the energy generation of the optimum-1 system will be 126219.5 kWh from solar PV, 577.09 kWh from wind turbine and 9181.47 kWh from bio-generator. The total annual energy generation of Optimum-1 system is 135978.1 kWh, which is higher than the annual energy demand (90841 kWh) of the institution. The gas emission result obtained from the HOMER Pro for optimum-1 and optimum-2 HRES is given in Table 3.

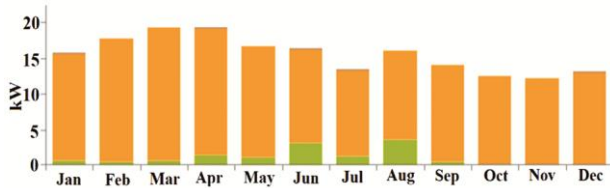

Fig. 11 — Monthly average power generation from the optimum-1 system

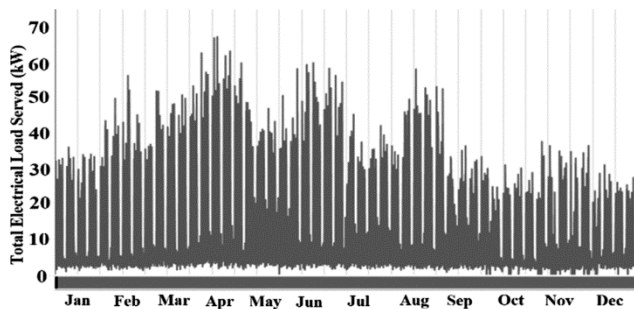

Fig. 12 — Annual power served to the load by optimum-1 system

If we compare the gas emissions of the proposed HRES with the conventional coal-based power plant, the gas emission of the conventional power plant would be 0.814 kg/kWh for CO₂, 4.631 g/kWh for CO, 5.823 g/kWh for SO₂, and 2.230 g/kWh for NO.²⁸ The annual energy generation of optimum-1 HRES is 135978.1 kWh, for generating the same amount of electrical energy, conventional coal-based power plant would emit 110686.17 kg of CO₂, 629.71 kg of CO, 791.8 kg of SO₂, and 303.23 kg of NO. The annual energy generation of optimum-2 HRES is 141898.8 kWh, for generating the same amount of electrical energy, conventional coal-based power plant would emit 115505.62 kg of CO₂, 657.13 kg of CO, 826.28 kg of SO₂ and 316.43 kg of NO. Hence, it can be stated that for same amount of electricity generation, gas emission from conventional coal-based power plant would be much higher than the gas emission from HRES optimum-1 and optimum-2. Therefore, it is suggested that in order to minimize the gas emission we can go for HRES instead of conventional fuel-based power plant.

Net Present Cost Break-up Analysis

NPC break-up analysis of HRES for optimum-1 and optimum-2 is given in Table 4 and Table 5 respectively. The total expenditure i.e. total cash outflow towards capital, replacement, O&M and fuel for optimum-1 is US \$ 185791.49. Considering the annual energy generation; 135978.1 kWh, cost of energy; US \$ 0.159/kWh, discount factor at the rate of 10%, the total earning for 25 years through energy generation by optimum-1 HRES is US \$ 196250.31. The total earnings of optimum-1 including the salvage

Table 3 — Total emissions generated by the HRES system

Description	Gas emission quantity in kg/year	
	Optimum-1 system	Optimum-2 system
Carbon dioxide	303	309
Carbon monoxide	39.9	36
Unburned hydrocarbons	0	0
Particulate matter	0	0
Sulfur dioxide	0	0
Nitrogen oxides	24.9	22.5

Table 4 — Net present cost break-up analysis of optimum-1 HRES

Component	Capital cost (\$)	Replacement cost (\$)	O & M cost (\$)	Fuel cost (\$)	Salvage cost (\$)	NPC (\$)
Battery	11475.00	19075.53	6711.26	0.00	0.00	37261.79
WT	883.50	0.00	319.58	0.00	0.00	1203.08
Bio-Gen	9400.00	0.00	2030.00	12781.33	13.28	24198.04
Solar PV	74894.11	0.00	25875.62	0.00	0.00	100769.74
Converter	9362.54	8147.28	4835.74	0.00	1090.73	21254.83
Complete System	106015.15	27222.80	39772.21	12781.33	1104.01	184687.48

Table 5 — Net present cost break-up analysis of optimum-2 HRES

Component	Capital cost (\$)	Replacement cost (\$)	O & M cost (\$)	Fuel cost (\$)	Salvage cost (\$)	NPC (\$)
Battery	10710.00	17803.82	6263.84	0.00	0.00	34777.67
WT	1767.00	0.00	639.17	0.00	0.00	2406.17
Bio-Gen	5640.00	1604.92	1711.95	12794.34	642.80	21108.41
Solar PV	78565.99	0.00	27144.24	0.00	0.00	105710.23
Converter	9387.93	8169.37	4848.86	0.00	1093.69	21312.47
Complete System	106070.92	27578.12	40608.06	12794.34	1736.48	185314.95

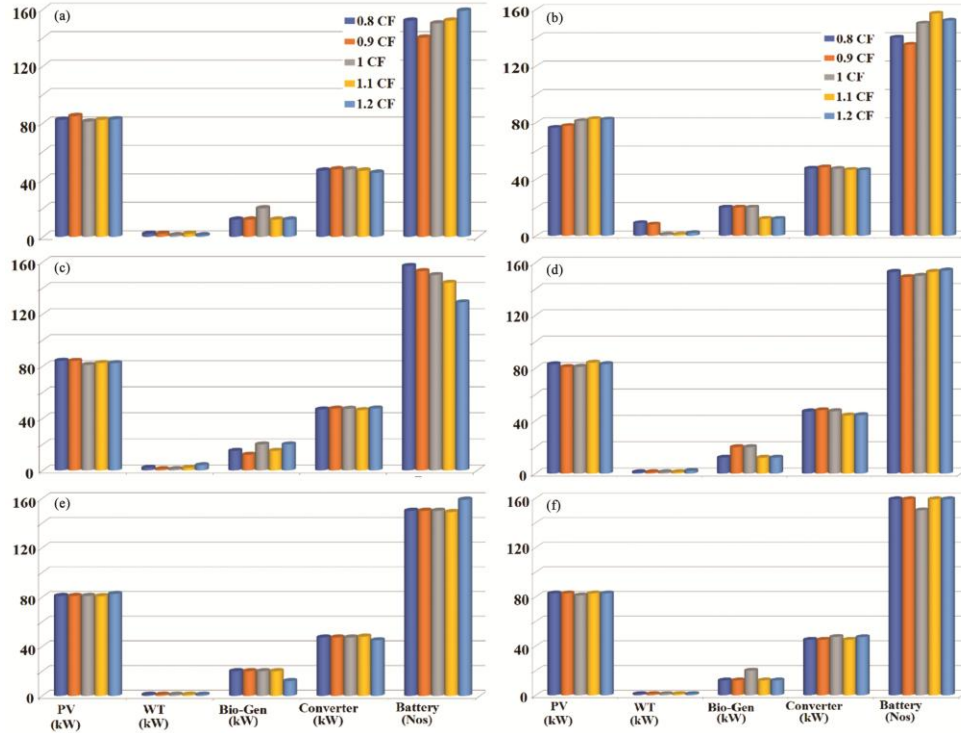

Fig. 13 — HRES Optimization on varying cost factor of (a) solar PV, (b) wind turbine, (c) battery, (d) converter, (e) bio-gen, and (f) fuel from 0.8 to 1.2

cost is US \$ 197354.32. Hence, the estimated NPC of optimum-1 on the basis of earnings from energy generation, discount factor for 25 years would be US \$ 11562.83. It may be noted that the NPC value shown in Table 4 has higher than the estimated NPC of optimum-1 which is mainly due to not considering the earnings through energy generation.

Similarly, the annual energy generation of optimum-2 is 141898.8 kWh and considering the same value for cost of energy as US \$ 0.159/kWh, discount factor as 10%, life time as 25 years, the total earning for 25 years through energy generation by optimum-2 is US \$ 204795.34. The total earning of optimum-2 including the salvage cost is US \$ 206531.82. Total cash outflow towards capital, replacement, O&M and fuel for optimum-2 is US \$ 187051.44. Hence, the estimated NPC of optimum-2 on the basis of earnings from energy generation, discount factor for 25 years would be US \$ 19480.39.

It may be noted that the NPC value shown in Table 4 has higher than the estimated NPC of optimum-2 which is mainly due to not considering the earnings through energy generation. Total outflow of optimum-2 is US \$ 187051.44 which is US \$ 1259.95 higher than the optimum-1. Optimum-2 system generates US \$ 9177.50 more earnings compared to optimum-1, hence optimum-2 can be selected based on high energy generation.

Sensitivity Analysis of System

Sensitivity analysis enables the investors to investigate into how the projected performance of HRES will vary along with changes in the cost of components used in HRES. It is also used to determine the risk factor in project capital budgeting decisions. In this present study the sensitivity analysis was done on varying the cost factor of solar photovoltaic, wind turbine, battery, bio-gen and fuel from 0.8 to 1.2, the results are shown in the following Fig. 13.

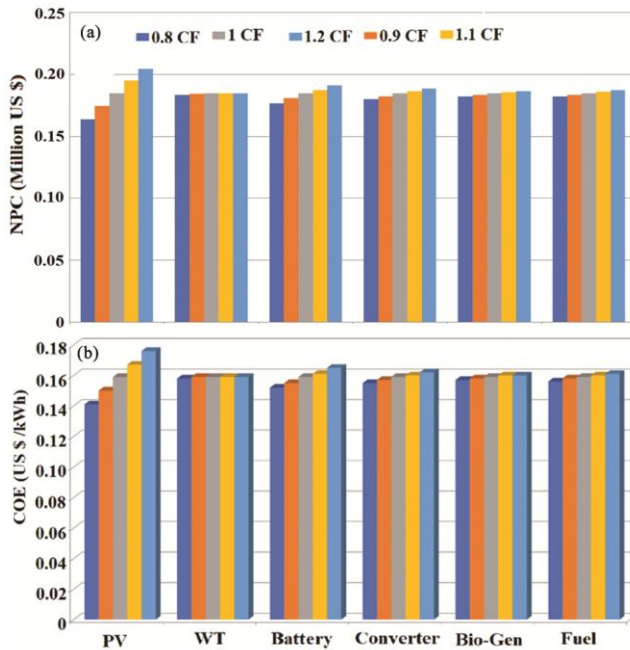

Fig. 14 — Effect on (a) NPC, and (b) COE upon variation of cost factor of solar PV, wind turbine, battery, bio-gen and fuel from 0.8 to 1.2

It has been observed from the sensitivity analysis as shown in Fig. 13 (a to f) that when there is 10% reduction in the cost of solar PV, the investor can think of rising the rating of solar PV slightly i.e., from 81 kW to 85 kW, wind turbine from 1 kW to 2 kW, reducing the capacity of bio-generator from 20 kW to 12 kW. If wind turbine cost reduces by 10%, the investor can think of rising the rating of wind turbine from 1 kW to 8 kW, and reducing solar PV rating from 81 kW to 78 kW. If the battery cost reduces by 10% or 20%, the investor can think of rising the number of batteries from 150 to 153 or 150 to 157 respectively.

If the battery cost increases by 10% or 20%, the investor can think of reducing the number of batteries from 150 to 144 or 150 to 129 respectively. The converter cost increases by 10%, the investor can think of reducing converter rating from 47 kW to 44 kW. If the bio-generator fuel cost increases up to 20%, investors can go for reducing the bio-gen rating from 20 kW to 12 kW. Effect of variation cost of HRES components on NPC and COE

can also be seen from the sensitivity analysis as shown in Fig. 14. It is observed that in general there is an increase in NPC and COE w.r.t increase in cost factor of the components from 0.8 to 1.2. It has been observed that effect of variation on cost of solar PV has the maximum effect on the NPC

and COE, i.e. it gives the best minimum NPC as US \$ 163958 and best minimum energy generation cost as US \$ 0.141 per kWh.

Conclusions

Sizing optimization and techno-economic analysis of hybrid renewable energy system (HRES) was executed in HOMER Pro. HRES is modeled in order to get minimum Net Present Cost (NPC) to meet the electrical load demand of an institution selected for this study. From an installed Energy Management System (EMS) the data on daily based average annual energy demand; total annual energy demand and maximum peak demand of the institution was recorded as 256.33 kWh/day; 90841 kWh/year and 71.37 kW respectively. In order to meet this energy and load demand, out of top 10 list of possible combination of the optimized HRES, two systems were selected (termed as optimum-1 and optimum-2) based on minimum NPC and higher energy generation. The rating of individual components of optimum-1 and optimum-2 consists of 81 kW and 85 kW for solar PV, 1 kW and 2 kW for wind turbine, 20 kW and 12 kW for bio-gen, battery rating 101 Ah, 12V-150 Nos and 140 Nos respectively. As per the analysis of sensitivity which was executed by changing the cost factor of the individual components of HRES from 0.8 to 1.2. The gas emission from HRES optimum-1 and optimum-2, is much lower than the, gas emission from conventional coal-based power plant. The Optimum-1 HRES can generate 1,35,978.1 kWh of energy annually, and optimum-2 HRES generates 1,41,898.8 kWh of energy annually. The excess energy generated in this proposed optimum-2 system can be either supplied to the neighboring buildings/institutes or can be exported to the grid. Even-though optimum-2 has higher energy generation, the cost of energy generated by renewable energy systems are decreasing day by day, while the material cost of HRES is not decreasing significantly. At the same time, exporting the power to the grid or to the nearby building requires extra arrangement for proper transfer of power and it also involves additional expenses. Hence, we recommend users or investors to go for selecting the optimum-1 system, as it has minimum NPC.

References

- 1 Chauhan A & Saini R P, A review on integrated renewable energy system-based power generation, for stand-alone applications: configurations, storage options, sizing methodologies and control, *Renew Sustain Energy Rev*, **38**(2014) 99–120.

- 2 Chong L W, Wong Y W, Rajkumar R K, Rajkumar R K & Isa D, Hybrid energy storage systems and control strategies for stand-alone renewable energy power systems. *Renew Sustain Energy Rev*, **66** (2016) 174–189, <https://doi.org/10.1016/j.rser.2016.07.059>
- 3 Tezer T, Yaman R & Yaman G, Evaluation of approaches used for optimization of standalone hybrid renewable energy systems, *Renew Sustain Energy Rev*, **73** (2017) 840–853.
- 4 Allison J, Robust multi-objective control of hybrid renewable microgeneration systems with energy storage, *Appl Therm Eng*, **114** (2017) 1498–1506, <https://doi.org/10.1016/j.applthermaleng.2016.09.070>
- 5 Cano M H, Agbossou K, Kelouwani S & Dube Y, Experimental evaluation of a power management system for a hybrid renewable energy system with hydrogen production. *Renew Energy*, **113** (2017) 1086–1098, <https://doi.org/10.1016/j.renene.2017.06.066>
- 6 Goel S & Sharma R, Performance evaluation of standalone, grid connected and hybrid renewable energy systems for rural application: A comparative review, *Renew Sustain Energy Rev*, **78** (2017) 1378–1389.
- 7 Kabalci E, Design and analysis of a hybrid renewable energy plant with solar and wind power, *Energy Conver Manag*, **72** (2013) 51–59, <https://doi.org/10.1016/j.enconman.2012.08.027>
- 8 Perez-Navarro A, Alfonso D, Ariza H E, Carcel J, Correcher A, Escriva-Escriva G, Hurtado E, Ibanez F, Penalvo E, Roig R, Roldan C, Sanchez C, Segura I & Vargas C, Experimental verification of hybrid renewable systems as feasible energy sources. *Renew Energy*, **86** (2016) 384–391. <https://doi.org/10.1016/j.renene.2015.08.030>
- 9 Reddy K S, Mudgal V & Mallick T K, Thermal performance analysis of multi-phase change material layer-integrated building roofs for energy efficiency in built-environment, *Energies*, **10(9)** (2017) 1367, <https://doi.org/10.3390/en10091367>
- 10 Reddy K S, Mudgal V & Mallick T K, Review of latent heat thermal energy storage for improved material stability and effective load management, *J Energy Storage*, **15** (2018) 205–227, <https://doi.org/10.1016/j.est.2017.11.005>
- 11 Yin C, Wu H, Locment F & Sechilariu M, Energy management of DC microgrid based on photovoltaic combined with diesel generator and super capacitor, *Energy Conver Manag*, **132** (2017) 14–27, <https://doi.org/10.1016/j.enconman.2016.11.018>
- 12 Yang H X, Lu L & Burnett J, Weather data and probability analysis of hybrid photovoltaic–wind power generation systems in Hong Kong, *Renew Energy*, **28(11)** (2003) 1813–24.
- 13 Yang H, Lin L & Zhou W, A novel optimization sizing model for hybrid solar-wind power generation system, *Sol Energy*, **81(1)** (2007) 76–84.
- 14 Mohammad S B & Mohsen N, Comparative performance analysis of a hybrid PV/FC/battery stand-alone system using different power management strategies and sizing approaches, *Int J Hydrog Energy*, **40(1)** (2015) 538–548.
- 15 Raji A & Yamada N, Optimization of a PV-wind-diesel system using a hybrid genetic algorithm, *IEE Electr Power Energy Conf EPEC*, (2012) 81–85.
- 16 Nasser A & Reji P, Optimal planning approach for a cost effective and reliable microgrid, *IEEE Int Conf Cogen Small Power Plants District Energy*, (2016) 1–6.
- 17 Bansal A K, Gupta R A & Kumar R, Optimization of hybrid PV/wind energy system using Meta Particle Swarm Optimization (MPSO), *India Int Conf Power Electron IICPE*, (2011) 1–7.
- 18 Saadi A, Mohammed K, Patrick C K L & Fei W, Impact of unit commitment on the optimal operation of hybrid microgrids, *UKACC 11th Int Conf Control*, (2016) 1–6.
- 19 Kaabeche A, Optimization of a completely autonomous hybrid system (wind photovoltaic), *Rev mater énerg renouv*, **9(3)** 2006, 199–209.
- 20 Tina G, Gagliano S & Raiti S, Hybrid solar/wind power system probabilistic modelling for long-term performance assessment, *Sol Energy*, **80(5)** (2006) 578–588.
- 21 Chua K H, Lim Y S & Morris S, Cost-benefit assessment of energy storage for utility and customers: a case study in Malaysia, *Energy Conver Manag*, **106** (2015) 1071–81.
- 22 Adaramola M S, Agelin-Chaab M & Paul S S, Analysis of hybrid energy systems for application in southern Ghan, *Energy Conver Manag*, **88** (2014) 284–95.
- 23 Zahboune H, Zouggar S, Krajacic G, Varbanov S P, Elhafyani M & Ziani E, Optimal hybrid renewable energy design in autonomous system using Modified Electric System Cascade Analysis and Homer software, *Energy Conver Manag*, **126** (2016) 909–922.
- 24 Canales F A & Alexandre B, Modeling pumped hydro storage with the micropower optimization model (HOMER), *J Renew Sustain Energy*, **6(4)** (2014) 043131.
- 25 Qolipour M, Ali M, Shahaboddin S, Omid A, Hossein G & Dalibor P, Evaluation of wind power generation potential using a three hybrid approach for households in Ardebil Province, Iran, *Energy Conver Manag*, **118** (2016) 295–305.
- 26 NASA Surface meteorology and Solar Energy database, Global horizontal radiation, monthly averaged values over 22 year period, July 1983 – June 2005.
- 27 NASA Surface meteorology and Solar Energy database, Wind speed at 50m, monthly averaged values over 10 year period, July 1983-June 1993.
- 28 Satyashree G, Rohit K, Navneet S & Himani K, Estimation of Green House Gas Emission from Indian Coal Based Thermal Power Plant, *IOSR J Eng*, **2(4)** (2012) 591–597.